



Introducing a game-changing investment.

[peelports.com](https://www.peelports.com)

Peel Ports Group
More Than Ports

Launching 2 STS Cranes

This project marks the **largest financial commitment** ever made to enhance Greenock's port facilities.

It stands as the **most strategic move**, fortifying Greenock's position in the global shipping industry.

The installation of **two new STS cranes** will allow Greenock to manage Post-Panamax vessels with greater efficiency, increasing its cargo handling capabilities.

As **Scotland's sole deep-water non-tidal port**, Greenock is ideally suited to accommodate large ships and pivotal maritime routes.

These improvements will forge new **international connections**, fostering economic growth and extending Greenock's global trade network.



The technology + build: STS cranes.

Cutting-edge ship-to-shore technology:

Installed with the latest ship-to-shore technology, supported by Liebherr, ensuring minimal outages.

Scotland's largest ship-to-shore cranes:

Featuring the largest ship-to-shore cranes in all of Scotland.

Post-panamax capability:

Equipped to handle Panamax and Post-Panamax ship sizes, enhancing Greenock's competitive edge among UK and European ports.

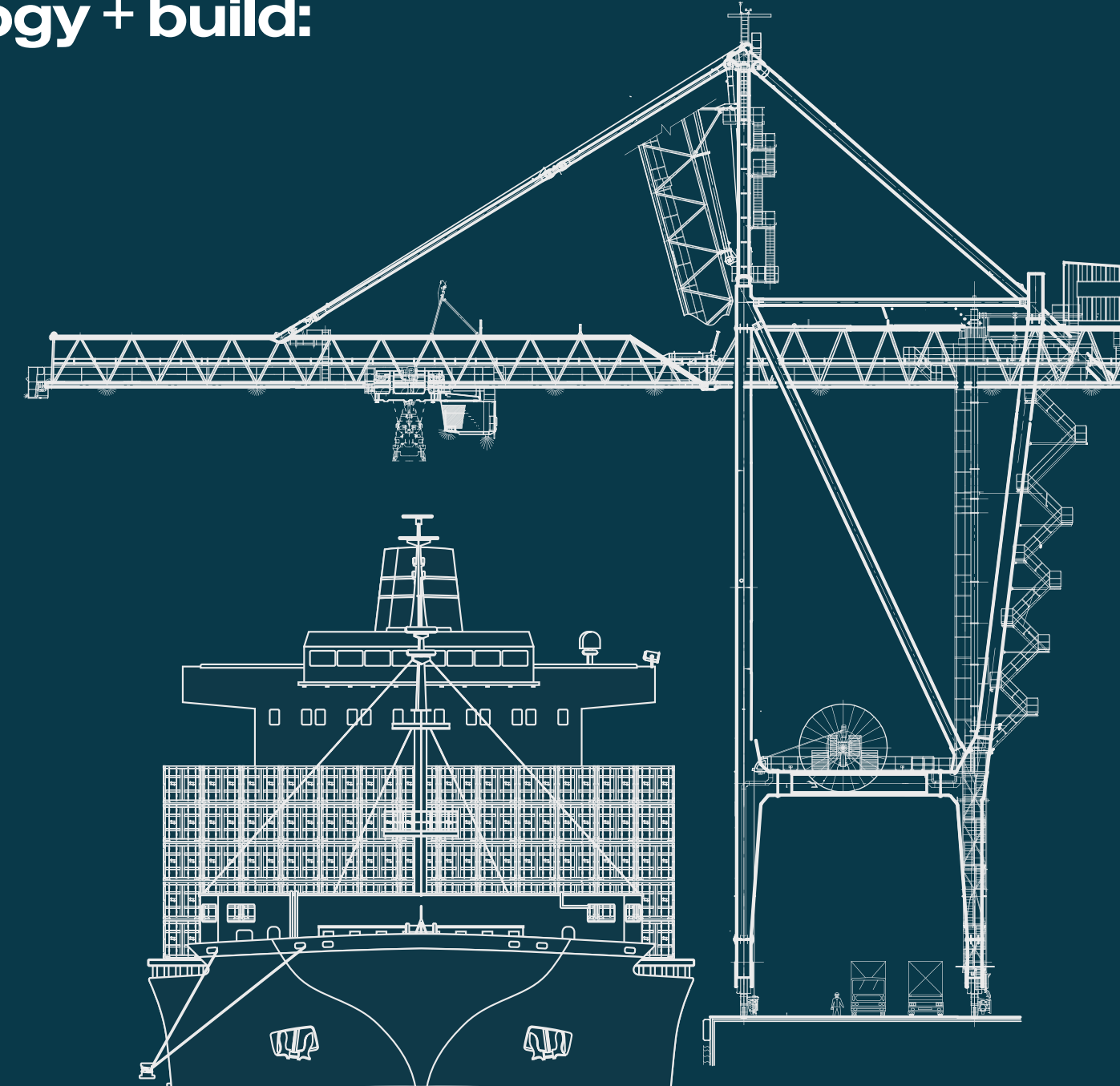

The Greenock cranes in numbers.

Facts and figures

£25m investment
2 years to build in Ireland
24/7 availability

Crane specifications

52.1m total spread
Handles **65** tons on hook
Handles **45** tons on spread

42.2m outreach

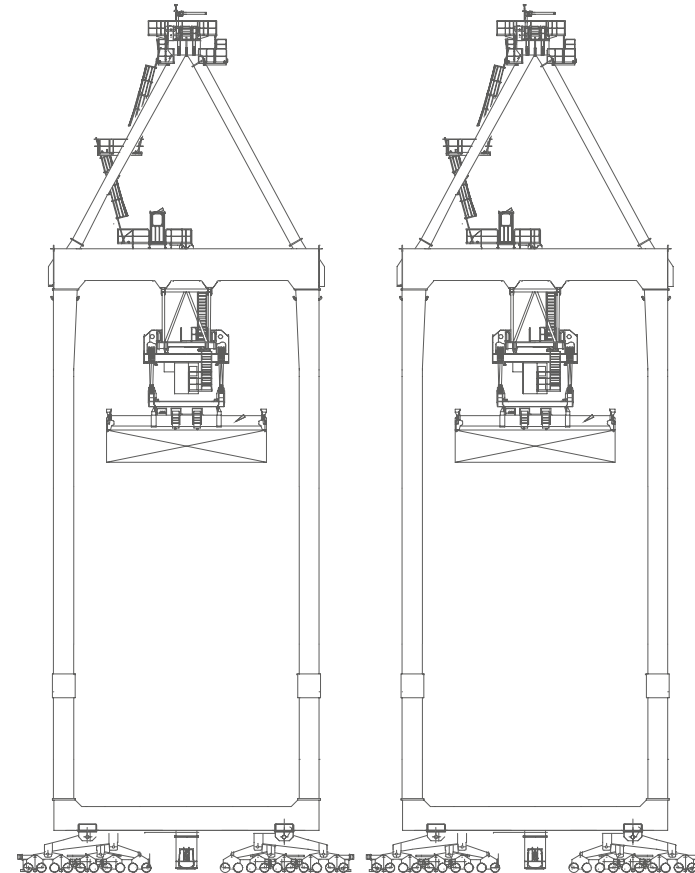

What this means for you.



Our new capacity to welcome Post-Panamax vessels opens direct sea connections between Scotland and the world.



Experience significantly reduced loading and unloading times, keeping your vessels on schedule.



With 17m higher and 7.5m longer outreach, we're ready for higher on-deck stowage and broader beams.



Our energy-efficient technology means reduced carbon emissions for your supply chain.



We have the ability to lash and secure any cargo regardless of shape or size.

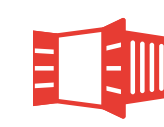

By providing a strip and load service onsite, we can help reduce your haulage costs.

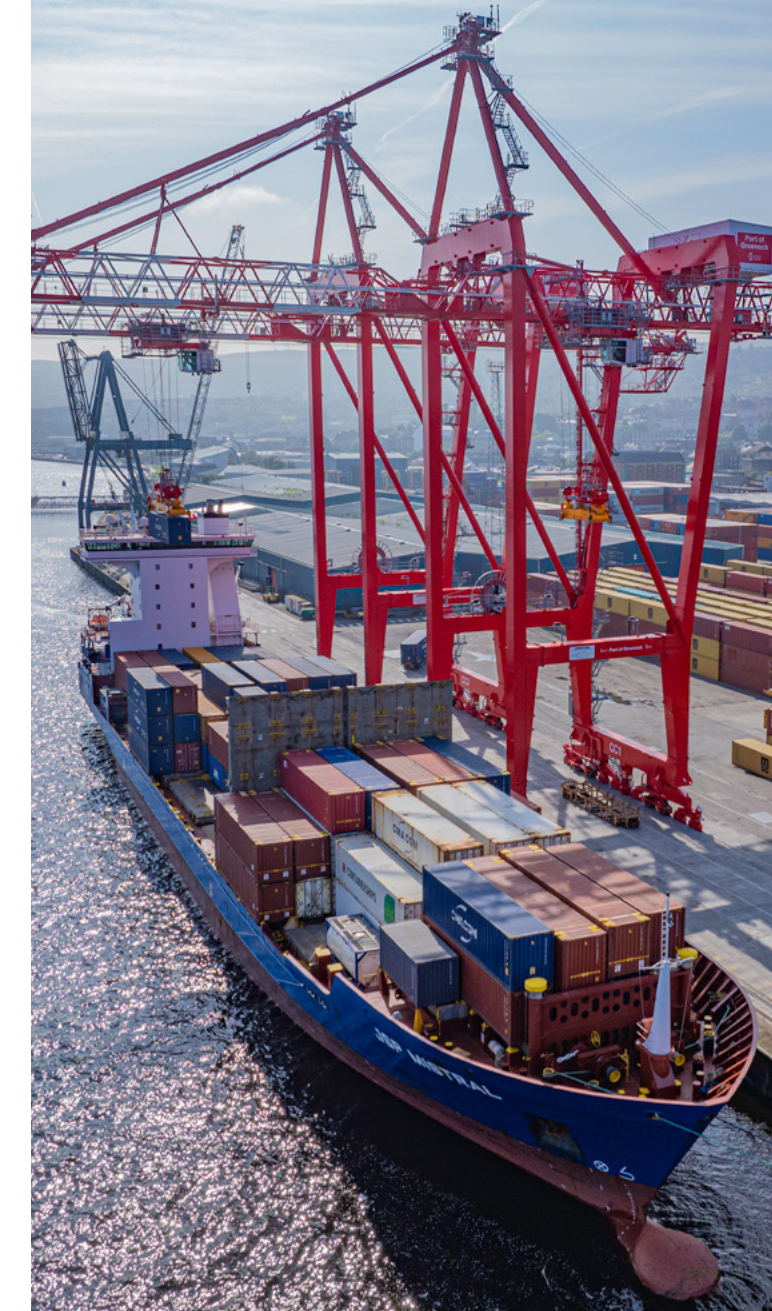

Creating opportunities.

Increase imports and exports:

The upgraded port will facilitate an increase in both imports and exports, driving economic growth.

Global cargo connectivity:

Enhanced infrastructure will seamlessly connect cargo from Greenock to global markets.

Expand customer base:

Businesses will have new opportunities to expand their customer base through improved shipping capabilities.

Proximity to end destinations:

The strategic location and advanced facilities will bring goods closer to their final destinations, reducing transit times.

Sustainable miles savings:

Efficient logistics will result in fewer miles travelled, promoting sustainability.

Efficient and sustainable services:

The new cranes and improved port operations will deliver a more efficient and environmentally friendly service.



A new hub for the entire world.

Access for deep water vessels:

Global shipping companies can now bring their deep water vessels directly into Greenock.

Transshipment hub:

Positioning Greenock as a crucial trans-shipment hub.

Strategic Irish sea location:

Utilising Greenock's prime location in the Irish Sea to enhance maritime logistics.

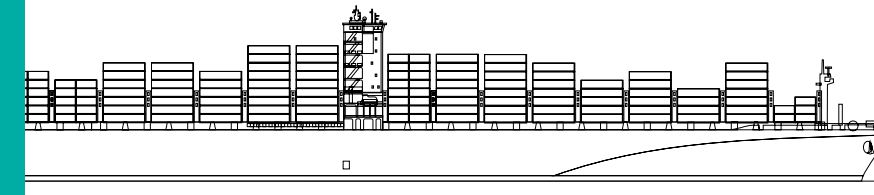



Port of Greenock

A complete logistics hub.

The Port of Greenock offers more than advanced cranes.

Our extensive on-site warehousing and upgraded reefer facilities support a wide range of cargo needs. For Scottish exporters, the Port of Greenock acts as the nation's gateway to Ireland and transatlantic Americas as well as European hubs.

With strong multimodal connections and partnerships, we ensure cargo moves efficiently from ship to destination, streamlining the entire supply chain process.

There's nothing we can't handle

At Peel Ports Group our teams have extensive expertise in handling every type of commodity.

From bulk to containerised goods and specialised project cargo to everything else in between, we have the flexibility, experience and capability to handle every commodity to meet the diverse needs of customers.



Cruise



Project Cargo

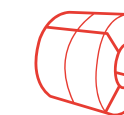

Steel & Metals



Forest Products



Reefer Points



Agri Bulks



Containers



Dry Bulks



Onshore & offshore energy



Decommissioning

Get in touch today!



James McSporrان

Port Director
Peel Ports Clydeport
james.mcsporrان@peelports.com
+44 (0)7394567176



Craig Collins

Senior Business Unit Manager
Peel Ports Clydeport
craig.collins@peelports.com
+44 (0)758 777 4365



Fraser Houston

Head of Sales
Peel Ports Clydeport
fraser.houston@peelports.com
+44 (0)7769 885944

Thank you



Peel Ports Group
More Than Ports



Peel Ports Group

Maritime Centre
Port of Liverpool
L21 1LA
0151 949 6000
www.peelports.com

peelports.com/sustainability



NET ZERO
2040

ENABLING
THE FUTURE

